

SECTIONAL DRAWING

TYPE: SUBMERSIBLE DRAINAGE PUMP

MODEL: FBM0.48-0.75kW

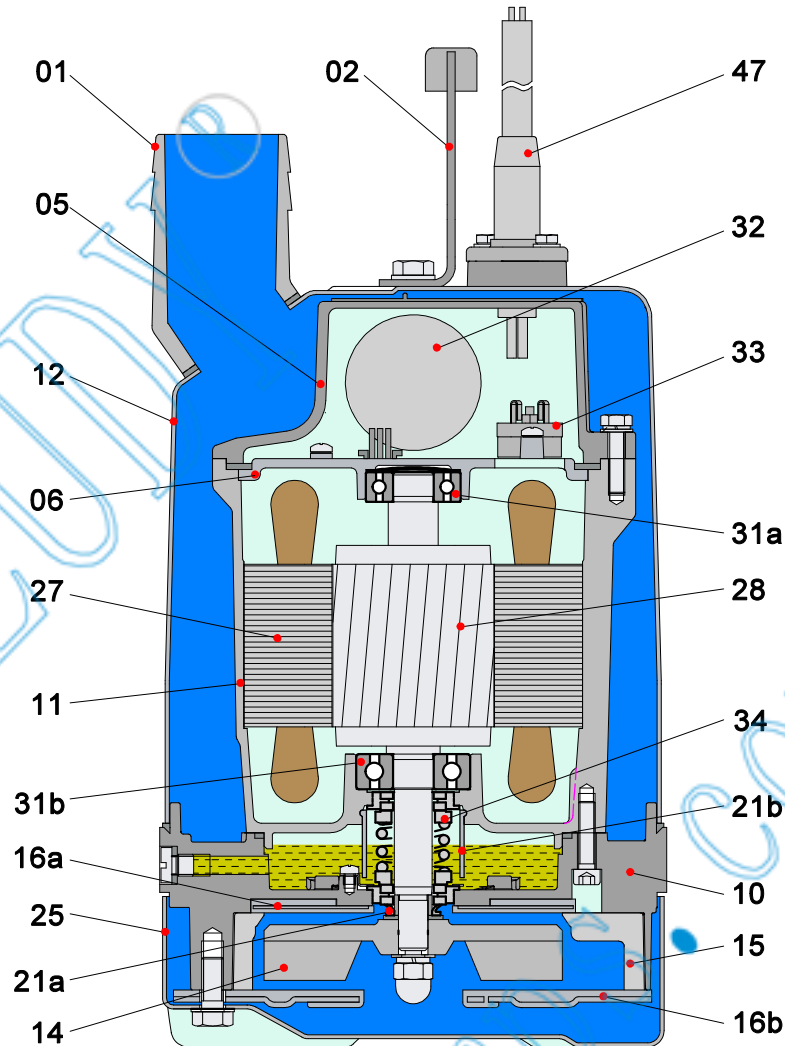

Item No.	Part name	Material	Item No.	Part name	Material
01	Hose coupling	Aluminum die casting	21a	Oil riser	NBR
02	Handle	Rubber & steel	21b	Sand guard	LDPE
05	Upper cover	Aluminum die casting	25	Strainer	Steel
06	Up-Bearing house	Cast iron	27	Stator	
10	Seal house	Aluminum die casting	28	Rotor	Shaft:AISI420SS
11	Motor body	Aluminum die casting	31a	Bearing	Ball bearing
12	Outer casing	Steel	31b	Bearing	Ball bearing
14	Impeller	TPU & AISI201SS	32	Capacitor	
15	Diffuser	NBR	33	Motor protector	
16a	Plate	TPU & Steel	34	Mechanical seal	Ceramic-Sic/Carbon-Ceramic
16b	Intel plate	TPU & Steel	47	Cable	H07RN-F

ZHEJIANG FENGYUAN PUMP INDUSTRY CO., LTD.

All rights reserved. This file are not allowed to be copied all or partially without permission.

DIMENSION DRAWING

TYPE: SUBMERSIBLE DRAINAGE PUMP

MODEL: FBM480

Model	N.W(kg)
FBM480	11.6

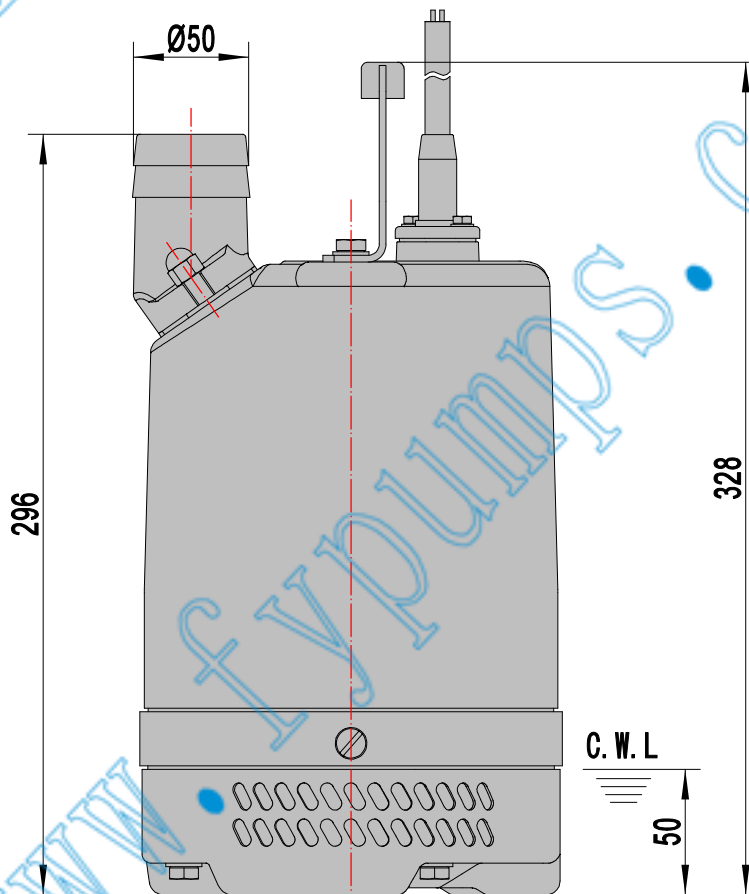
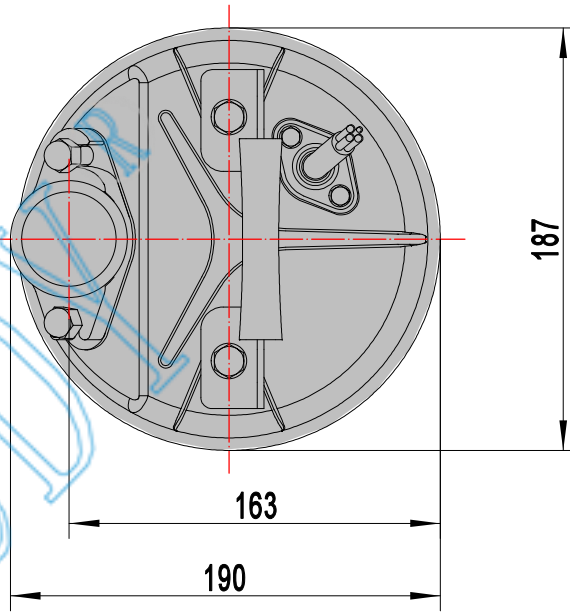

C.W.L:Continuous Running Water Level.

ZHEJIANG FENGYUAN PUMP INDUSTRY CO., LTD.

All rights reserved. This file are not allowed to be copied all or partially without permission.

PUMP PERFORMANCE CURVES

TYPE: SUBMERSIBLE DRAINAGE PUMP		MODEL: FBM480	FREQUENCY: 50Hz
STANDARD SPECIFICATIONS			
DISCHARGE BORE	50 mm		
HEAD	Max: 11.5 m	Rated: 8 m	
CAPACITY	Max: 0.23 m ³ /min	Rated: 0.12 m ³ /min	
MOTOR OUTPUT	0.48 kW		
PHASE x VOLTAGE	1 Øx 230 V		
CURRENT	3.0 A		
POLES/REVOLUTION	2 P/ S.S.2850 min ⁻¹		
STARTING METHOD	Direct-on-line start		
INSULATION CLASS	F		

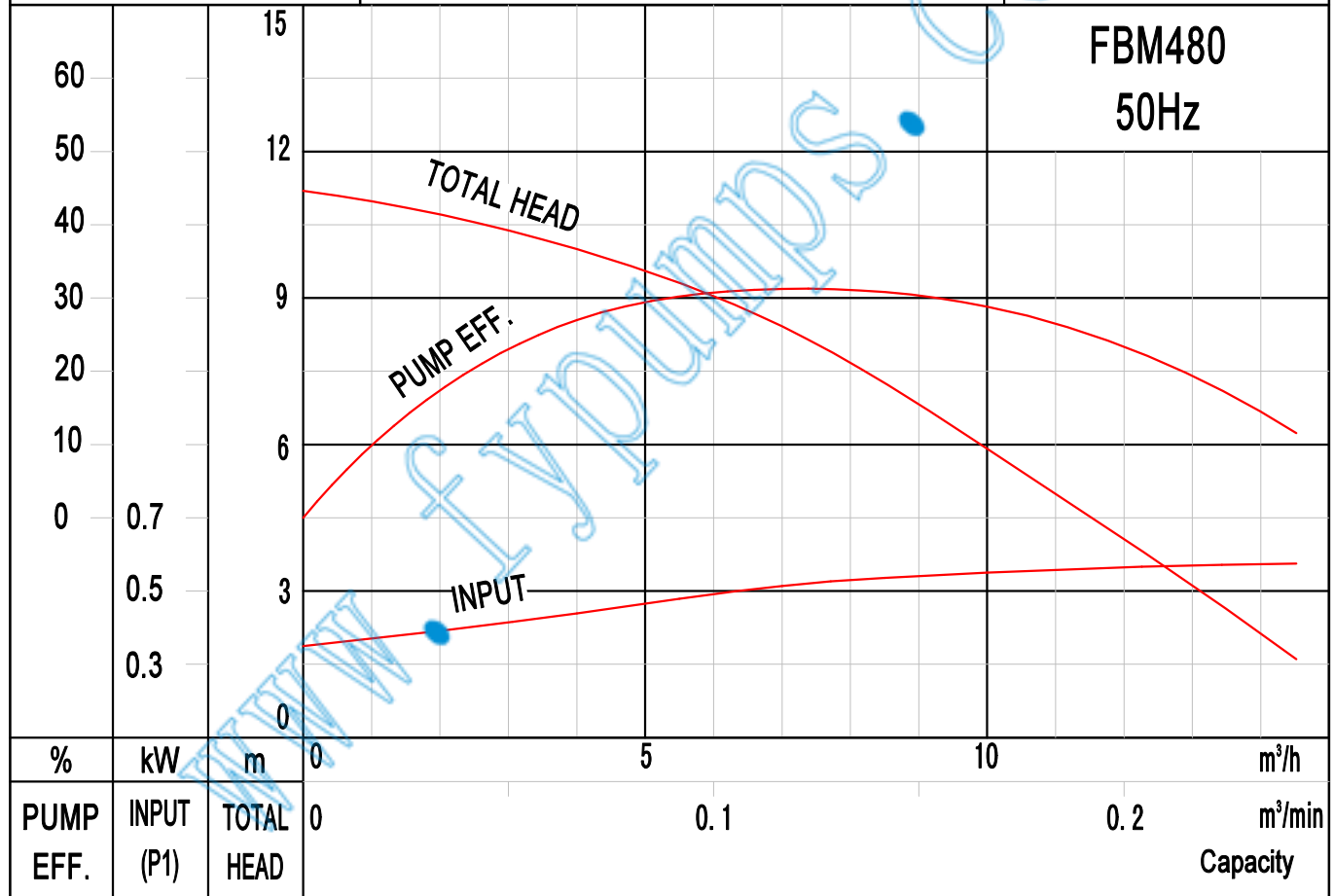

ZHEJIANG FENGYUAN PUMP INDUSTRY CO., LTD.

All rights reserved. This file are not allowed to be copied all or partialy without permission.